

Solenoid valve injector

System pressure up to 1350 bar

► Type: CRI1

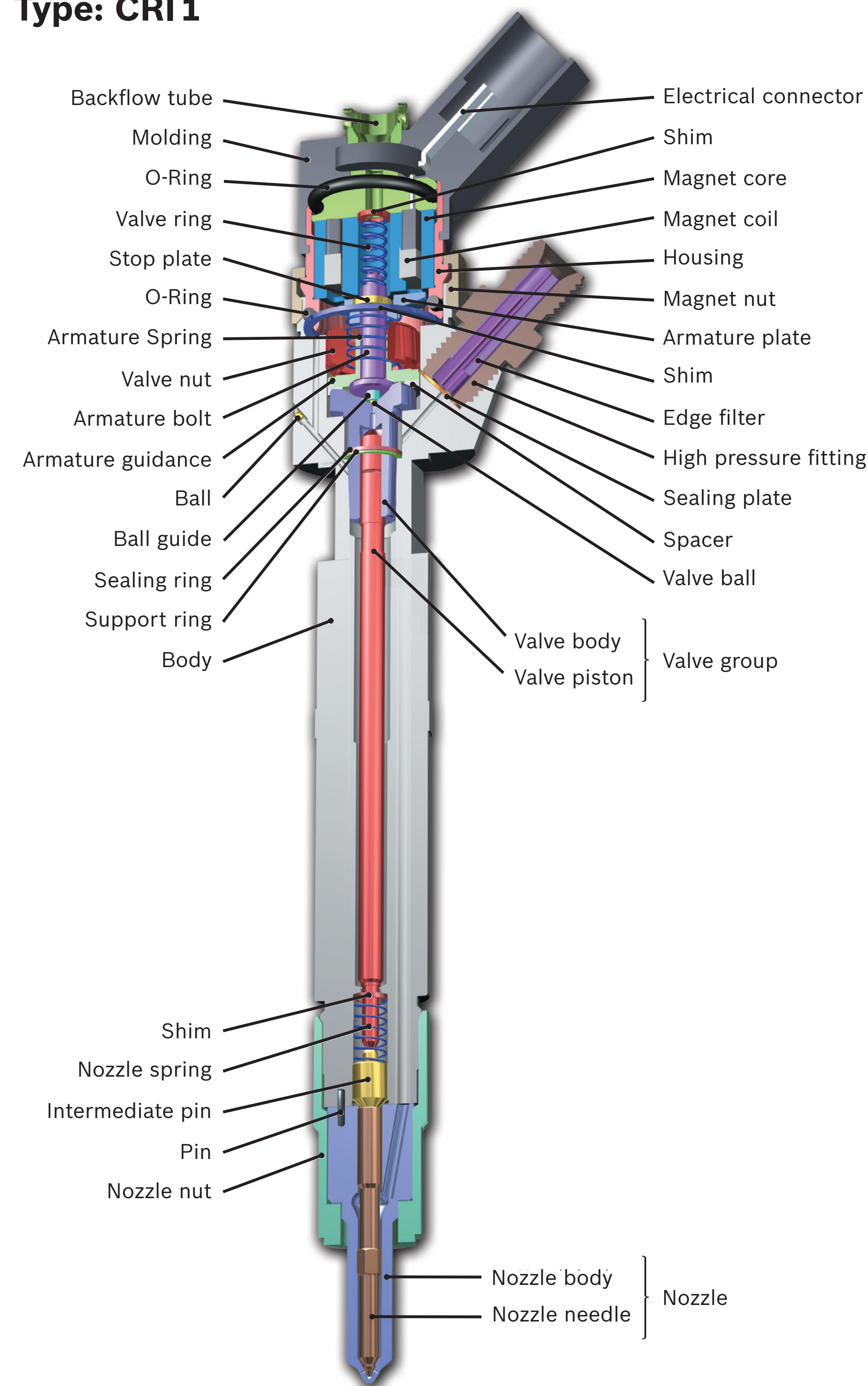

Armature

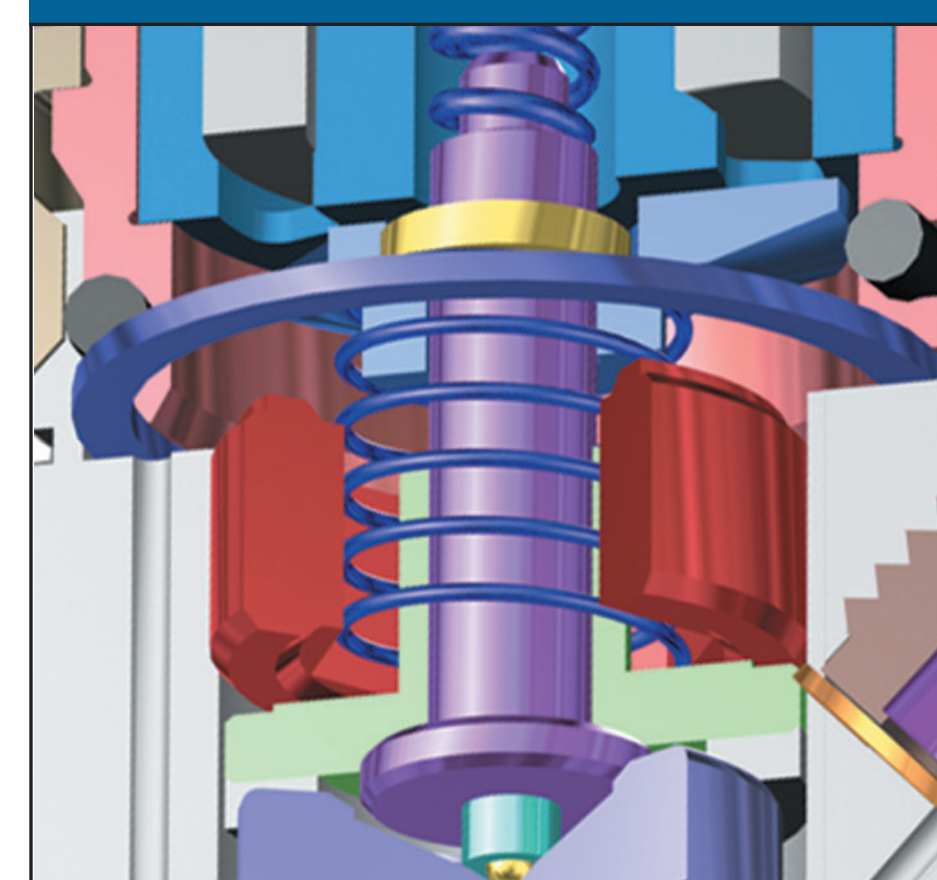

Valve Body

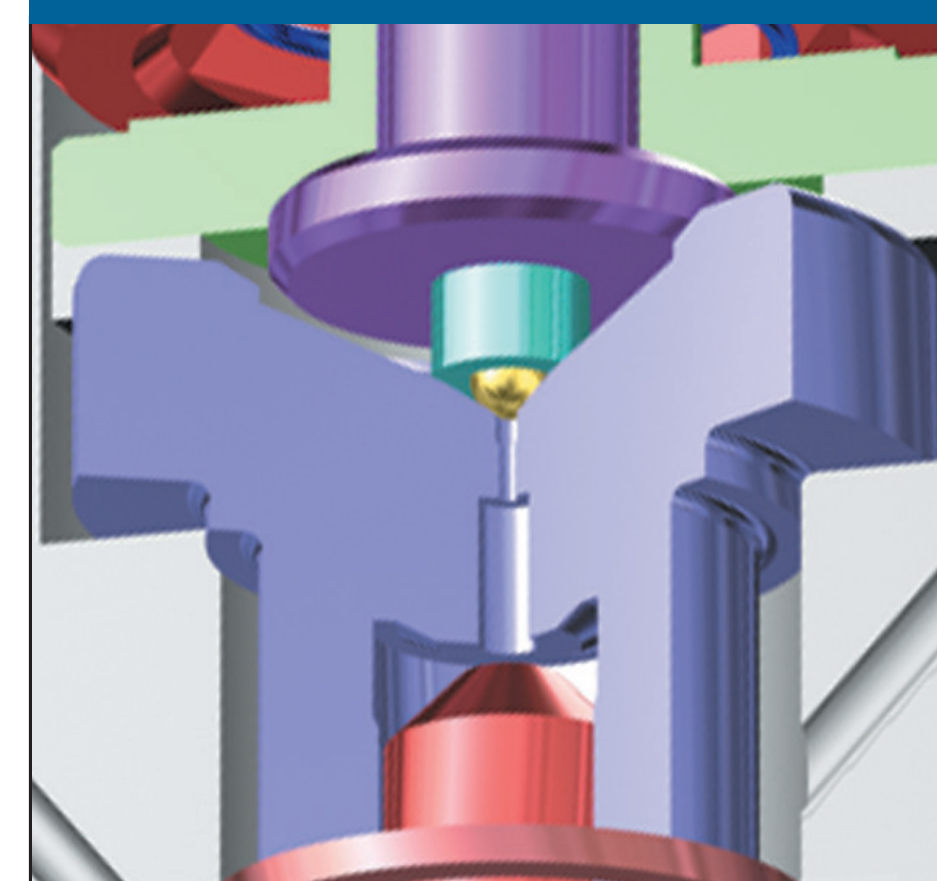

Piezo Injector

System pressure up to 2000 bar

► Type: CRI3.0

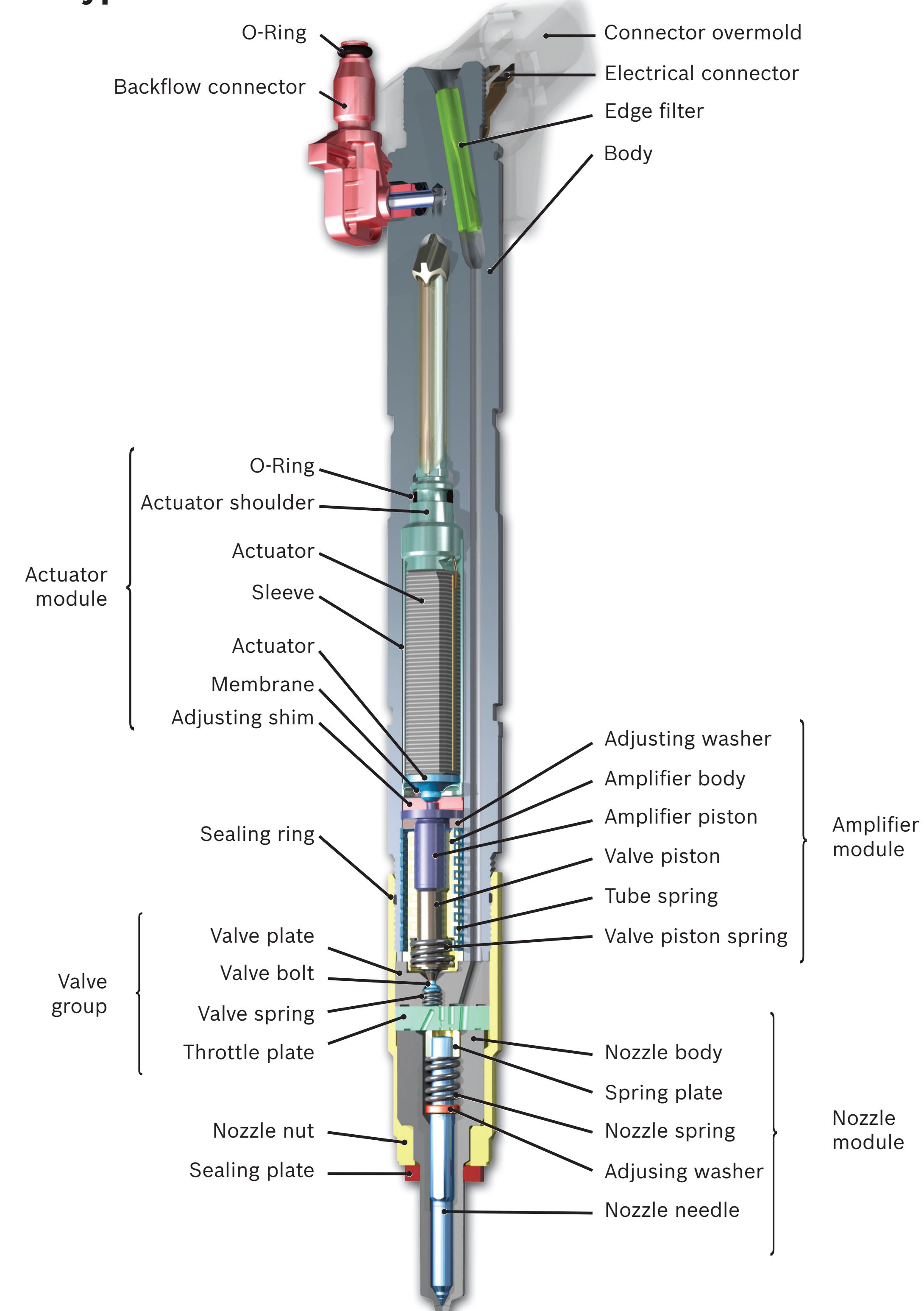

Actuator Module

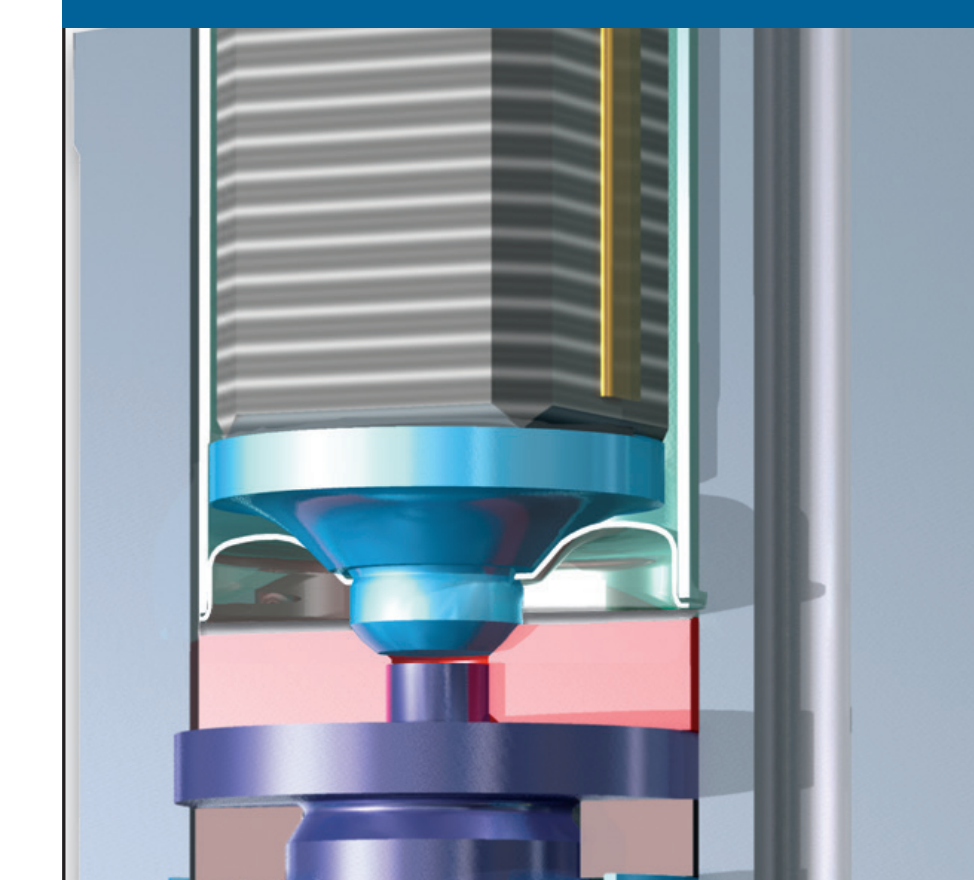

Amplifier Module

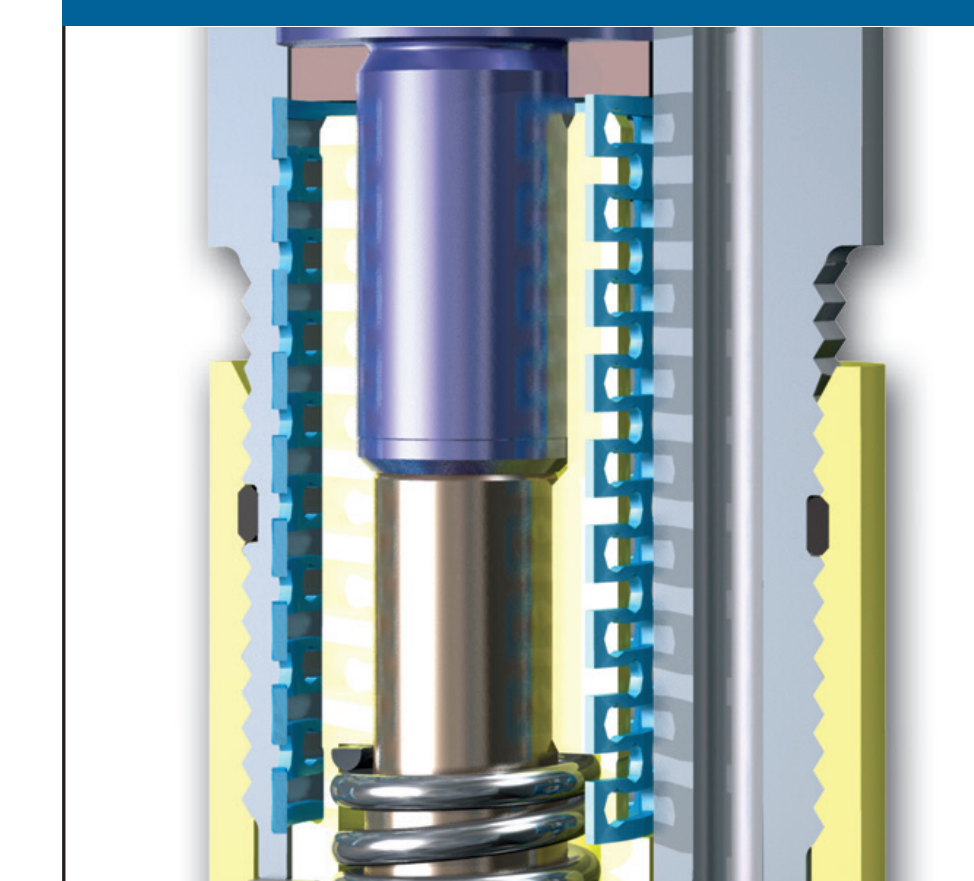

Valve Group

